

# ELLIS FLATWORK IRONERS

## Features:

### Flexibility:

The Ellis Flatwork Finishing System includes a variable speed drive with interconnection capabilities to make the system work as a single system with the feeder and folders. This allows the operator to change from product to product without extensive down time.

### Expandability:

The Ellis Flatwork System can be modified by expanding the number of rolls to meet production requirements. By adding rolls you can accelerate the speed of the ironer to accommodate increased productivity.

*The 32", 48" and the 60" diameter roll ironers are manufactured in modular design with heated gap pieces for transfer from roll to roll. The modular design of the rolls allows you to add rolls for more productivity. The more heated surface the goods travel the better the finish."*

### Chest Design:

### Steam:

The sectional steam chest cavity is designed to deliver the energy from the steam to the surface of the chest for even thermal transfer, while maintaining a single chest to roll contact surface for a better finish. This eliminates cool spots, reduces chemical deposits, and delivers a better finished product. The deeper steam cavity, troughs, and sectioned compartments remove condensate quickly and keep the condensate away from the chests. Condensate resting against the chest will cause cool spots and waste energy. The Ellis chest design breaks the steam chamber into two sections on the first chest. The first 30% of the chest, where most of the condensate is created because this is where the product being finished is coolest, is sectioned off with its own separate steam feed, trough, and steam trap. The second chest cavity of the first chest, approximately 70% of the surface, again has its own separate steam feed, trough, and steam trap.

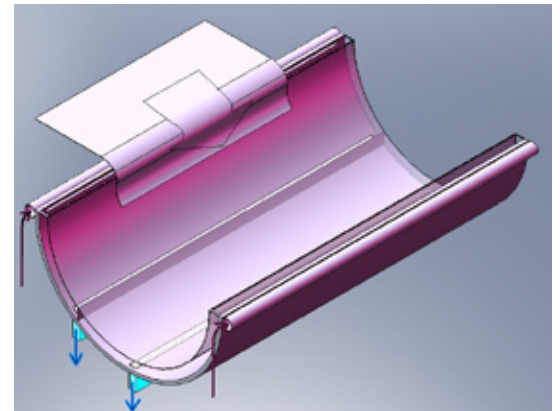

Combined with the deeper cavity:

- The condensate has enough clearance not to run along the back of the chest surface, but on the bottom of the cavity;

# ELLIS FLATWORK IRONERS

## Features (cont'd):

- The trough allows the condensate to collect away from the chest making it easier to maintain temperature on the chest surface;
- The sectioned chest allows the removal of the condensate where most of it is created, at the feed end of the first chest;

(Typical hydro formed chests have very small, typically 2-3mm, steam cavities behind the chest surface and are continuous across the entire chest from front to rear. Most of the condensate is created at the coolest point of the chest, the point of entry of the cooler goods to be finished at the lead end of the first chest, where it must drain through the chest to the bottom of the chamber to the steam traps, and all of the condensate created in the cavity must travel along the same path to the steam traps.)

### Thermal Oil:

The thermal oil chest design is sectioned as well, and for the same reason, to keep constant even temperatures across the surface of the chest while maintaining a single chest to roll contact surface for a better finish. The difference is that the thermal oil chests are 'channeled' to force constant flow and create turbulence in the oil. The turbulence is needed to keep the surface of the chest clean and eliminate the build up on the back of the chest. The channeling creates the turbulence, but also does not allow pockets to be created where the oil can cool of because it is not flowing.

Like the steam chest, the thermal oil chest cavity is sectioned as well while maintaining a single chest to roll contact surface for a better finish. The difference is that the thermal oil chest has three cavities with their own separate hot oil feed from a common header and return lines back to the thermal exchanger.

The benefit, again, is a constant temperature on the heated surface, reduction of chemical deposits, a cleaner chest, and a better finished product.

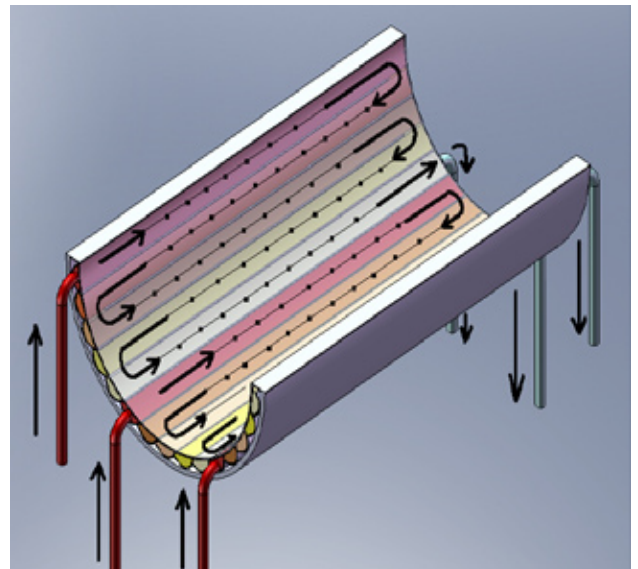

*The rolls are lifted out of the chests by two air cylinders on each side of the ironer. By lifting the rolls we achieve open access to the chests for polishing scratches on the surface. It is also an extremely important safety feature because if the safeties are tripped or the power is interrupted, the rolls automatically lift out of the chests and stop. Other designs do not allow access to the chests without disassembling the ironer to take the rolls out.*

# ELLIS FLATWORK IRONERS

## Features (cont'd):

### Features & Safety and Maintenance:

The Ellis chest type flatwork finishing system includes a few key features that improve maintenance and minimize down time.

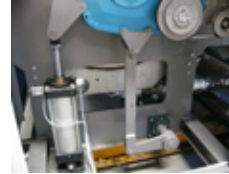

The features of the Ellis ironer include:

- The rolls lift out of the chest for easier access for cleaning or buffing scratches (other designs require removing the roll for access to the chest);
- The torsion bar design guarantees constant even pressure across the entire width of the roll to chest contact surface.
- The steam traps are located down the side of the ironer behind the side guards for easy access;
- The steam system is pre-piped with welded flanges for easy maintenance, reliable performance, and simple utility termination;
- Independent vacuum dampeners on each roll for better drying and faster production;
- The Ellis ironer includes automatic roll pressure reduction when items cease to be fed into the unit; once items begin to be fed again the rolls automatically return to the set pressure;



*The independent vacuum for each roll increases the drying capacity of the ironing system.*

*The steam piping and traps run along the side frames for easy access and maintenance.*

- The drive from roll to roll is done by v-belt with gear reduction;



*The drive and lifting cylinders are easily accessed at the sides of the ironer.*

- Easy access to electrical components;



*The electrical panel and components are located behind the controls at the left front corner of the ironer.*

# ELLIS FLATWORK IRONERS

## Features (cont'd):

- The ironer is insulated to optimize the energy usage;
- The controls indicate chest temperature, roll pressure, exhaust temperature, and ironer speed;



*The controls are easy to access at the feed and of the ironer. They can also be integrated into the feeder controls to set speed and system configuration automatically. The controls display exhaust temperature, chest temperature, ironer speed, and roll*

### Energy:

The high production chest type ironers are available in steam heated, thermal oil heated, and self-contained thermal oil heated designs. These offer our customers a wide variety of energy sources to use, even if you do not have a boiler in your operation.

### Standard Features Include:

- Springs & Padding
- Internally Piped and Trapped
- Insulation
- Variable Speed Inverter Drive
- V-Belt Drive and Power Take-Off
- Digital Display of Chest Temperature, & Speed, Roll Pressure
- Independent Vacuum for Each Roll

### System Integration:

As pointed out earlier, the flatwork ironer is designed to be integrated with the Ellis feeding and folding devices.

### Service, Warranty, and Support:

Ellis has the largest service and support staff in the industry. We offer training both on site, regionally, and at our offices in Chicago for all of our customers.

(Due to product development designs are subject to change without notice, so please contact our office for the latest features)



**Laundry Machinery, Flatwork Finishing Systems**

1400 West Bryn Mawr Avenue  
Itasca, Illinois 60143

[www.elliscorp.com](http://www.elliscorp.com)